

AirCare Max-5

Alternating Air Mattress Overlay

User Manual



Premium*Lift*

CONTENTS

WARNINGS & CAUTIONS	4-5	
GENERAL INFORMATION	6-10	
1	DEFINITION OF THE GROUPS MENTIONED	6
2	NON-COMPLIANT USE	7
3	SAFETY INSTRUCTIONS	7
3.1	GENERAL SAFETY INSTRUCTIONS	7
3.2	SAFETY INFORMATION FOR THE OPERATOR	8
3.3	SAFETY INFORMATION FOR THE USER	8
3.4	SYMBOLS USED	9
3.5	CLEANING & DISINFECTION	10
3.6	SERVICING & MAINTENANCE	10
3.7	SERVICE LIFE & DISPOSAL	10
TECHNICAL SPECIFICATION	11	
OVERVIEW	12	
INSTALLATION	13	
CLEANING & CARE	14-15	
ROUTINE MAINTENANCE	16-17	
TROUBLESHOOTING	18-21	
PARTS LIST	22	
GUARANTEES & WARRANTIES	23	

WARNINGS & CAUTIONS



READ THIS INSTRUCTION MANUAL AND OBSERVE SAFETY INSTRUCTIONS.



WARNING

- This system must be properly installed and operated as directed by this user manual.
- The system should be checked regularly to ensure correct operation. Loss of function will remove all pressure relieving properties that this system provides.
- This system is intended for use as part of a pressure ulcer prevention program; do not rely solely on this device to achieve the result. The medical professional is responsible for applying best medical judgment when using this system.
- Select the correct setting for the occupant's weight and therapy required. Care should be taken not to accidentally change pressures once set as the effectiveness of the therapy may be reduced.
- In order for alternating air pressure range to be effective, avoid placing objects on the surface that may obstruct the movement of air between the cells. For the same reason, discourage people from sitting on the edge or on the end of the mattress whilst it is in use.
- All hoses must be free of kinks, twists and must be properly connected and positioned so as not to cause any obstruction.
- Do not position the system in a way that prevents access to the disconnection device (mains power plug).
- Ensure the mains lead or pump cannot become trapped or crushed, e.g. by raising or lowering of bed or bed rails or any other moving object.
- Check the mains lead is damage free and positioned so as not to cause an obstruction, or injury, e.g. strangulation or trip hazard.
- Ensure that the electricity supply is of the type stated on the pump unit.
- Protect your system from open flames. Ensure that the system is not used in the presence of flammable anaesthetics.
- Do not place device on or near a heat source or cover pump with bedding.
- PremiumLift advise against smoking whilst the system is in use, to prevent the accidental ignition of associated items which may be flammable, such as bed linen.

WARNINGS & CAUTIONS

- Do not expose the pump to liquids.
- Do not use with hot water bottles or electric blankets.
- Wireless equipment such as mobile phones should be kept at least 10ft / 3m away from the system.
- Do not allow sharp objects to puncture the mattress material.
- The mattress and pump should be cleaned between patient uses.
- Do not use bleach, chlorine releasing agents in concentrations over 1000 ppm, solvents or alcohol-based cleansers, e.g. Phenicol, Hibiscrub, Clearsol, Stericol, Hycoline as these will destroy the mattress material. Full cleaning instructions can be found on **page 14-15**.
- Suitable for continuous use.
- Do not modify the mattress or pump unit in any way.
- Do not connect to any other medical device or equipment.
- Not for use in an oxygen enriched environment.
- Not for use in an outdoor environment.
- Store the system in a clean and dry environment, out of direct sunlight.



Electrical equipment can be hazardous. Only authorised technical personnel should remove the rear pump case for maintenance. Removal of the case by unqualified personnel will invalidate the warranty.



Before cleaning the unit ensure that the electrical supply to the pump has been disconnected by removing the plug from the power supply.



Do not use this system for lifting the patient. This will damage the system and could put the patient at risk.



This product is fire rated. Use of this product should be subject to a risk assessment in which all hazards are considered.

GENERAL INFORMATION



BEFORE USING THIS SYSTEM FOR THE FIRST TIME:

- Read through this Instruction Manual conscientiously from start to finish.
- Please note that the various safety instructions must be observed.

PremiumLift products bear the CE and TGA mark and meet all safety and functionality requirements.

These safety requirements can only be met if the user is satisfied with the proper condition of the product (including accessories) before use.

GENERAL INFORMATION

The **AirCare Max-5 Overlay System** is an alternating pressure relieving mattress system used in the prevention and treatment of pressure ulcers, and is recommended for use by a patient who is at risk from developing pressure sores. The mattress is fitted with a vapour permeable two way stretch cover.

By using the established principles of alternating therapy, the **AirCare Max-5 Overlay System** offers the patient comfortable and relaxing support that can both prevent tissue breakdown and enhance healing.

The **mattress** is made up of 18 individual cells. 15 alternating air cells and 3 static pillow section cells. The alternating cells are split into 2 sections - odd cells e.g. 1,3,5 etc and even cells e.g. 2,4,6 etc. These two sections will alternate through a cycle in which time both sets of air cells will have inflated and deflated sequentially. All air cells are individually replaceable should any damage occur.

The connector has transport cap to maintain the air pressure within the mattress, for easy patient transport arrangements. For rapid deflation of the system simply pull open the CPR and disconnect the pump.

1 DEFINITION OF THE GROUPS MENTIONED

OPERATOR

An operator is any natural or legal person who uses the equipment or on whose instruction it is used (e.g. nursing homes, specialised retailers, health insurance companies, medical suppliers).

GENERAL INFORMATION

USER / CARE PERSONNEL

Users are persons who as a result of their vocational training, experience or briefing are authorised to operate the equipment.

Furthermore, the user/ care personnel can recognise and avoid potential dangers and assess the clinical condition of the service user.

PATIENT / OCCUPANT / SERVICE USER

The person in need of care, handicapped or infirm.

QUALIFIED PERSONNEL

Qualified personnel are employees of the operator who as a result of their vocational training or briefing are entitled to deliver, assemble, disassemble and transport the product.

2 NON-COMPLIANT USE

All uses deviating from the intended purpose, which may also be hazardous as a result. This includes for example:

- Incorrect installation.
- Operation by persons who have not been instructed in its use.
- Using the system with non-approved parts/accessories.
- Using the system if any of the components are damaged or faulty.

3 SAFETY INSTRUCTIONS

3.1 GENERAL SAFETY INSTRUCTIONS



During the briefing, specific attention must be drawn to any potential dangers which can occur despite correct operation. Before putting the product into service for the first time, the Instruction Manual must be read conscientiously and in detail by the user / care personnel.

Programming of the system should be carried out by competent trained personnel.

Use only spares and accessories supplied or approved by PremiumLift.

Only suitably trained personnel are allowed to operate the system.

GENERAL INFORMATION



The mains cable must be free and not be allowed to be caught up in the bed's moving mechanisms. The mains cable may be torn out of its strain relief and damaged or it may be pulled out of its socket and electric leads exposed as a result.

If the mains cable or the mains plug are damaged, the relevant part must be replaced. This work should be carried out by the manufacturer or authorised service agents.

When connecting the mains plug do not use multiple sockets since liquids may penetrate into these (fire hazard and electric shock).

3.2 SAFETY INFORMATION FOR THE OPERATOR



With the help of this Instruction Manual, instruct each user in the safe operation of this system before it is put into service for the first time.

Advise the user of any hazards which may occur if not handled correctly.

Only persons who have been properly instructed may operate this system. This also applies for persons who only operate the system on a temporary basis.

3.3 SAFETY INFORMATION FOR THE USER

Ensure that the operator instructs you in the safe operation of this system.

In addition, pay particular attention to the Warnings and Cautions (**page 4-5**) and the general safety information as described in **3.1**.

If there is a suspected fault or damage, unplug the mains plug from the socket and follow the power down procedure (**page 16**). Clearly mark "Out of Order" and take out of service immediately, and inform the person in charge without delay.

GENERAL INFORMATION

3.4 SYMBOLS USED



This symbol indicates general hazards. There is a danger to life and health.



Conformity mark in accordance with the Medical Device Directive (93/42 EEC).



The symbol for Protection Class I device, double insulated.



The symbol for Medical device according to EN 60601-



Handle with care



This way up



Keep dry



Recycling symbol. Refers to packaging that can be recycled (cardboard)



Fragile, handle with care



This product must be disposed of in a designated refuse bin for waste electronic devices (WEEE) in the European Union. Do not dispose of as normal domestic waste.



No smoking. No naked flames.



Read instructions / consult manufacturers guide



This symbol indicates electrical hazards. There is danger to life and health.

GENERAL INFORMATION

3.5 CLEANING & DISINFECTION



Do not immerse electrical components in water but wipe with a damp cloth only. The electrical components must not be cleaned with a high-pressure cleaner or water jet. Disinfection by wiping only is allowed.

Full cleaning and disinfection instructions can be found on **pages 14-15**.

3.6 SERVICING & MAINTENANCE



Servicing must only be carried out by qualified personnel.

A technical check and/or safety inspection must be conducted at least once a year and after a lengthy break in use.

Any defects, damage or signs of wear must be rectified without delay. Only original spare parts from PremiumLift may be used, otherwise all guarantees or warranties will be excluded.

See **pages 16-17** for Routine Maintenance and Servicing.

3.7 SERVICE LIFE & DISPOSAL



The system must not be disposed of as normal domestic waste after its service life, but must be disposed of in a designated refuse bin for waste electronic devices (WEEE) in the European Union. Do not dispose of as normal domestic waste.

Our Full Terms & Conditions including product warranties are available by request or can be found on our website www.premiumlift.com.au



PARTS AND DATA MAY UNDERGO FURTHER DEVELOPMENT AND THEREFORE DEVIATE FROM THE DETAILS GIVEN.

TECHNICAL SPECIFICATION

AIRCARE MAX-5 TECHNICAL SPECIFICATION

Product Code	ACMAX5S/ ACMAX5KS
Pressure Sore Risk Level	High to Very H.
Minimum Patient Weight	30 kg
Maximum Patient Weight:	150 kg
Dimensions	2000 x 900/1060 x 120 mm
Mattress Weight	8 kg

OVERVIEW

SYSTEM OVERVIEW



CPR Pull Tab

The mattress can be rapidly deflated through the use of the CPR pull tab, allowing emergency personnel to begin resuscitation.



Mattress Cover

The cover comprises of a two-way vapour permeable and a stitched stretch PU top with a durable base fabric.

AirCare Max-5 Cells

The Max-5 has 18 independent cells which can be individually removed and replaced to allow for cost effective repair and in-depth cleaning.

INSTALLATION

INSTALLING THE AIRCARE MAX-5 SYSTEM

- 1 Remove the mattress from its packaging and lay the parts out on the floor. You should have the following items:

- System Packaging
- Mattress with feed tubes attached
- Instruction booklet



If you intend to keep this mattress system in storage at some point please retain the packaging. This will lengthen the life of the mattress.



Prior to installing the mattress, check that there are no protruding/sharp objects which may puncture the cover or air cells.

- 2 Carefully unroll the mattress. Ensure that the pipes at both the head and foot ends are kink free and straight to prevent restriction of air flow. Ensure that the air tubing to the pump is at the foot of the bed.
- 3 Tuck and secure the straps to the bed profiling parts, do not fix to the bed frame and mattress.
- 4 The pump has integral bed hooks for hanging the pump on the foot end of the bed.



The pump and feed tubes should be at the foot end of the bed.

- 5 Check that the CPR pull tab is **CLOSED**.



The mattress will not inflate if the CPR pull tab is open.

- 6 Connect the feed pipes to the pump using the quick release coupling and ensure the connection has securely clicked into place.
- 7 When the mattress is ready to be inflated, insert the mains plug into the wall socket and turn on the power to the pump. Refer to the pump user guide.

CLEANING & CARE



WARNING

Ensure that the mains power supply to the pump is disconnected before cleaning

Eye protection, gloves and protective clothing should be worn when carrying out cleaning and disinfection procedures

When disinfecting the system, Harvest Healthcare recommends the following guidelines which have been developed to comply with recognised infection control procedures. These procedures are also to be used to prevent cross infection when transferring the system between patients.

MATTRESS

During general use the mattress and internal tubes can be cleaned by wiping with a mild detergent solution.

Where necessary the mattress cover can be removed for laundering or sterilisation. Where there is staining or body fluids on the mattress, cells or tubing, wash thoroughly with soap and water, then wipe with a sodium hypochlorite solution diluted to 1000ppm before laundering.

Mattress covers may be laundered as follows:

- 1 Pre-wash Cold 10 minutes
- 2 Main Wash 85°C 10 minutes
- 3 Followed by cold rinses and extraction.



Do not use abrasive cleaners, phenol disinfectants, solvents or alcohol-based cleansers, e.g. Dettol, Phenicol, Hibiscrub, Clearsol, Stericol, Hycoline, as these will damage the cover materials.



Do not iron.



Ensure that the mattress/cushion is thoroughly dried before remaking the bed or placing in storage.



HYPERCARBONATE AND PHENOL-BASED SOLUTIONS SHOULD NOT BE USED AS THESE WILL DAMAGE THE MATTRESS COVER

CLEANING & CARE

PUMP

For general cleaning wipe with a soft cloth dampened with a mild detergent and water solution. This may be followed by either wiping with a sodium hypochlorite solution to a dilution of 1000ppm (parts per million) or by using alcohol wipes.



DO NOT USE HYPERCARBONATE, PHENOL-BASED CLEANING SOLUTIONS, ABRASIVE COMPOUNDS OR CLEANING PADS.

NOTES

- Following the use of a detergent and or disinfectant solution rinse the mattress cover with clean water using a clean cloth and allow to dry.
- Frequent or prolonged exposure to high concentrations of disinfectant solutions will reduce the useful life of the mattress cover.
- Where high concentration disinfectants e.g. > 10,000ppm chlorine releasing agent (e.g. Haztab or bleach) or combined cleaning/chlorine releasing agent (e.g. Chlorclean, Actichlor) and detergent solutions are used to remove blood or other body fluids, mattresses should be thoroughly rinsed with clean water to remove any residues. This will help prevent any long term compatibility issues associated with disinfectant residues.
- Alternatively, disinfection may be achieved by laundering at temperatures not exceeding 80°C for 10 minutes which may include a chlorine rinse.

TRANSPORT & STORAGE

Storage conditions as follows:

-15 °C without relative humidity control; and +40 °C at a relative humidity up to 93%, non-condensing. An atmospheric pressure range of 700 hPa to 1 060 hPa. Suitable for all standard modes of transport when in the correct packaging.

Operation Conditions:

A temperature range of +5 °C to +35 °C; A relative humidity range of 15% to 93%, non-condensing; and Operational Atmospheric Pressure: 700 hPa to 1060 hPa. Suitable for pollution degree 2. Operational altitude ≤ 2 000 m.

Transportation of the mattress system:

The mattress should be loosely rolled lengthwise with the cover innermost, taking care not to strain the feed pipes. It can then be stored / transported in the carry bag with the pump, mains cable and this booklet. Do not stack bagged mattresses more than two high.

ROUTINE MAINTENANCE

These checks should be carried out at each decontamination process, i.e. between patients or patient occupancy and weekly for longer term patients.

MATTRESS

The mattress cover, which is made from waterproof and vapour permeable material, should be kept clean. Take care to avoid puncturing cover with sharp objects whilst performing the maintenance checks:

- 1 Remove cover and inspect for damage, tears or staining, which could lead to contamination of the internal parts.
- 2 Check that the zips are sound and in good working order.
- 3 Check that all connectors are fitted properly to prevent leaking of air.
- 4 Check that all cells are attached to the base sheet by the pop fittings provided.
- 5 Check the stitching on the straps and the seams to ensure no tearing or fraying has occurred.

PUMP

- 1 Check the pump casing for cracks or other damage that could be dangerous.
- 2 Check the power cord (ensure there are no bare wires).

If any faults are detected report to your distributor for replacements to facilitate repairs.

COMPONENTS

- Check air cells and mattress interior for signs of damage or contamination, e.g. staining or fluid ingress at each decontamination process, i.e. between patients or patient occupancy (or weekly for longer term patients).
- The individual cells can be wiped clean with a mild antiseptic solution.
- All cells are replaceable and can be sourced from Harvest Healthcare.

POWER UNIT

Disconnect the power unit from the electricity supply before carrying out maintenance, repairs or cleaning.

Check all electrical connections and power lead for signs of wear and damage. The power unit can be wiped down with detergent, disinfectant solution or wipe*. Do not use solvents. Unsuitable for sterilisation.

ROUTINE MAINTENANCE

- * In line with the MHRA Medical Device Alert (MDA/2013/019), PremiumLift advises customers to use pH neutral, high-level disinfectant cleaning products to sanitise reusable medical devices to prevent damage to materials and the degradation of plastic surfaces after prolonged use.
- The use of inappropriate cleaning and detergent materials on medical equipment could damage surfaces and may compromise the ability to decontaminate medical devices adequately or may interfere with device function

At end of use dispose of the pump / mattress in accordance with the local regulations including WEEE requirements, which apply to the pump and SMPS only.

SERVICING YOUR SYSTEM

The AirCare Max-5 system should be serviced every **12 months** by PremiumLift approved personnel using genuine PremiumLift spare parts.



Failure to follow the AirCare Max-5 service schedule may invalidate future warranty claims (Gurantees & Warranties can be found on page 23).

TROUBLE SHOOTING

FAULT	CHECK THAT	STAGE 2 CHECK	IF PROBLEM PERSISTS
<p>Pump shows no indication that it is powered up.</p>	<ol style="list-style-type: none"> 1. Mains plug is plugged in and power switched on. 2. The power switch on the pump is switched on. 3. The fuse in the mains plug is not blown. 4. The wall socket that the pump is connected to is working correctly. 	<ol style="list-style-type: none"> 1. Connect the pump to the nearest (working) mains outlet. 2. Replace the plug fuse with the correct 5A fuse. 3. Try a different device in the mains outlet. 	<p>Contact PremiumLift technical support.</p> <p>Before calling:</p> <p>Please ensure you have the serial number and model of equipment.</p> <p>Please record details of the results of the recommended tests. (Notes pages are provided at the back of this user manual).</p>

FAULT	CHECK THAT	STAGE 2 CHECK	IF PROBLEM PERSISTS
<p>The Pump appears to be running but the mattress is not inflating correctly and / or the low pressure light is illuminated.</p>	<p>PLEASE NOTE Inflation can take up to 30 minutes.</p> <ol style="list-style-type: none"> 1. The hoses are routed correctly (not kinked) and connected to the pump correctly. 2. The CPR valve is not trapped and is in the closed position. 	<ol style="list-style-type: none"> 1. Disconnect and then re-connect the hoses to the outlet on the side of the pump. 2. Open then reclose the CPR valve, make sure the valve is not trapped in the bed mechanism. 	<p>Contact PremiumLift technical support.</p> <p>Before calling:</p> <p>Please ensure you have the serial number and model of equipment.</p> <p>Please record details of the results of the recommended tests. (Notes pages are provided at the back of this user manual).</p>
	<ol style="list-style-type: none"> 1. There are no leaks in the mattress. 2. The tubes in the mattress are not disconnected or kinked. 	<ol style="list-style-type: none"> 1. Replace any damaged or leaking mattress parts with the correct genuine PremiumLift spare parts. 2. Straighten out any kinked pipes and reconnect any disconnected joints. 	

TROUBLE SHOOTING

FAULT	CHECK THAT	STAGE 2 CHECK	IF PROBLEM PERSISTS
<p>Some of the cells appear to be deflated.</p>	<p>This is normal for alternating pressure therapy.</p> <p>The mattress is made up of individual air cells. The alternating section is split up into 2 sections consisting of odd cells e.g. 1,3,5 etc and even cells e.g. 2,4,6 etc. These two sections will alternate through a 10 minute cycle in which time both sets of alternating air cells will have inflated and deflated sequentially.</p>		
<p>The system does not appear to be alternating.</p>	<ol style="list-style-type: none"> 1. Check that the static mode is not turned on. 2. Carefully mark one of the inflated cells with a pen. 3. Ensure that there are no kinks in the pipework down the side of the mattress. 	<ol style="list-style-type: none"> 1. Monitor the cell for 7 minutes to see if it deflates. 2. Straighten out any kinked pipes. 	<p>Contact PremiumLift technical support.</p> <p>Before calling:</p> <p>Please ensure you have the serial number and model of equipment.</p> <p>Please record details of the results of the recommended tests. (Notes pages are provided at the back of this user manual).</p>

FAULT	CHECK THAT	STAGE 2 CHECK	IF PROBLEM PERSISTS
The pump is vibrating or making excessive noise.	The pump is fitted to the bed correctly	Reposition the pump unit.	Contact PremiumLift technical support.
The mattress is uncomfortable.	Check the comfort setting on the pump.	Set the pump to the correct setting using the guide on the front of the pump case.	<p>Before calling:</p> <p>Please ensure you have the serial number and model of equipment.</p> <p>Please record details of the results of the recommended tests. (Notes pages are provided at the back of this user manual).</p>

PARTS LIST

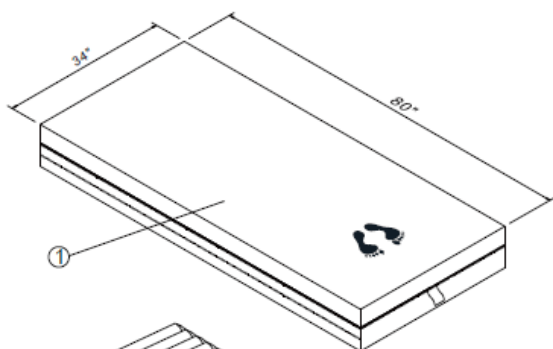

6	Quick Connector	ACM5-6
5	T Conector	ACM5-5
4	Air tube & CPR	ACM5-4
3	Cells	ACM5-3
2	Mattress Base	ACM5-2
1	Mattress Cover	ACM5-1
No.	Parts	SKU

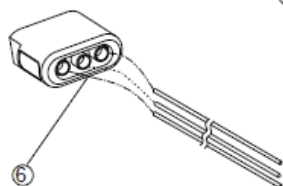
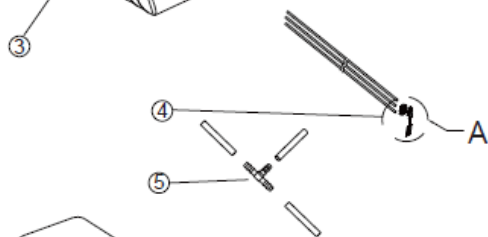
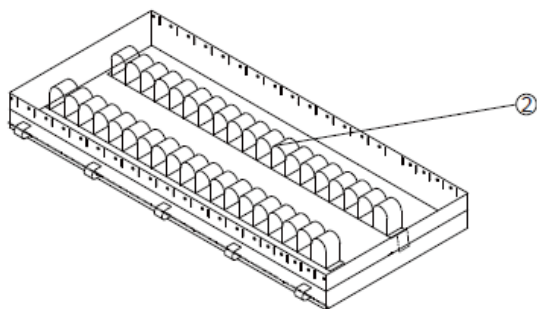
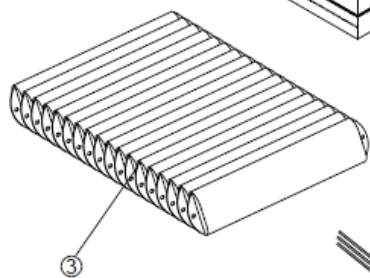

GUARANTEES & WARRANTIES

MATTRESS (COVER AND INTERIOR COMPONENTS)

All PremiumLift Mattress are covered by a 2 year limited warranty from date of purchase. Damage through incorrect use and penetration by sharp instruments will invalidate this warranty.

GUARANTEE

PremiumLift guarantees to repair or replace all goods supplied to its customers which are found to be defective whilst still in their applicable warranty period. All warranties are subject to the following conditions:

- a Warranty/ guarantee is subject to all guidelines being adhered to.
- b That the equipment has been used for the purpose for which it was intended.
- c That the usage has been on a fair wear and tear basis. This does not include user damage.
- d That PremiumLift's cleaning/ disinfecting guidelines have been followed.
- e PremiumLift's maintenance guidelines have been followed (Please refer to the product manual).
- f That ALL maintenance has been carried out by a suitably qualified and competent person.
- g That all parts used are OEM (Original Equipment Manufacturer) parts and were supplied by PremiumLift either directly or through a distributor.
- h All warranties begin from the time the product leaves the premises of PremiumLift
- i All repairs and replacements will be at the sole discretion of PremiumLift Ltd.

Our standard terms and conditions of sale can be found on our website or by request to PremiumLift

AirCare

Alternating Air Mattresses



PremiumLift

TGA Approved
Medical Device

Address: 1 Force Way Pakenham VIC 3810 Australia

T 1800 771 381

E sales@premiumlift.com.au

www.premiumlift.com.au

All parts and data continually undergo further development and may therefore deviate from the details given.

© **Copyright PremiumLift**

Our Full Terms & Conditions are available by request or can be found on our website. PremiumLift reserves the right to alter or amend this document without notice

Distributor Stamp:

